

# AKD8/AKR Modification for adding GTU w/RELT

The following information is to be used as a guide to modifying AKD8 equipment and AKR breakers in the field for the addition of the Entelliguard GTU (global trip unit) with the RELT option. Actual installation on your specific job may differ.

# AKD8/AKR Modification for adding GTU w/RELT

## Things to check in Switchgear before ordering:

### What are present functions on trip units?

You need to know functions to be able to order replacement trip units. If trip unit has LI or LS you'll need to order LSI on the Entelliguard replacement trip unit. The S and I functions are switchable on or off.

### Does the breaker have a programmer disconnect?

Check to see if breaker has a programmer disconnected mounted on the left side of the breaker. If so is it a 12 pin black disconnect plug or a 24 pin slate red plug. See the following pages for ordering information.

### Does the breaker have a conversion kit 9 pin communications plug installed?

If the breaker does not have the programmer disconnect you need to check if a conversion kit with a 9 pin communications plug was installed. This plug would have been used for communications and for connection of 24VDC to the breaker trip unit. See the following pages for ordering number.

# AKD8/AKR Modification for adding GTU w/RELT

## Does the breaker have communications?

If the breaker has communications wired in the switchgear it must be changed from Comnet to Modbus. This requires changing the wiring from the programmer disconnect terminal block or conversion kit with a 9 pin communications plug all the way to the mod bus concentrator. The current wiring would have been Belden 8719. It needs to be replaced with Belden 9841(RS-485) cable. The Modbus concentrator needs to be removed if all breakers are being updated. If not all breakers are being updated the breaker modified needs to have updated wiring and the wiring must bypass the modbus concentrator.

## Does switchgear has 24VDC installed?

If 24VDC is present then you just need to check how many trip units are being powered by the power supply. With the addition of the power requirements of the RELT option the maximum number of breakers on a power supply is now 15. If you have more breaker trip units on a power supply you must add additional power supplies.

# RELT Switch Wire Harness

AKD8

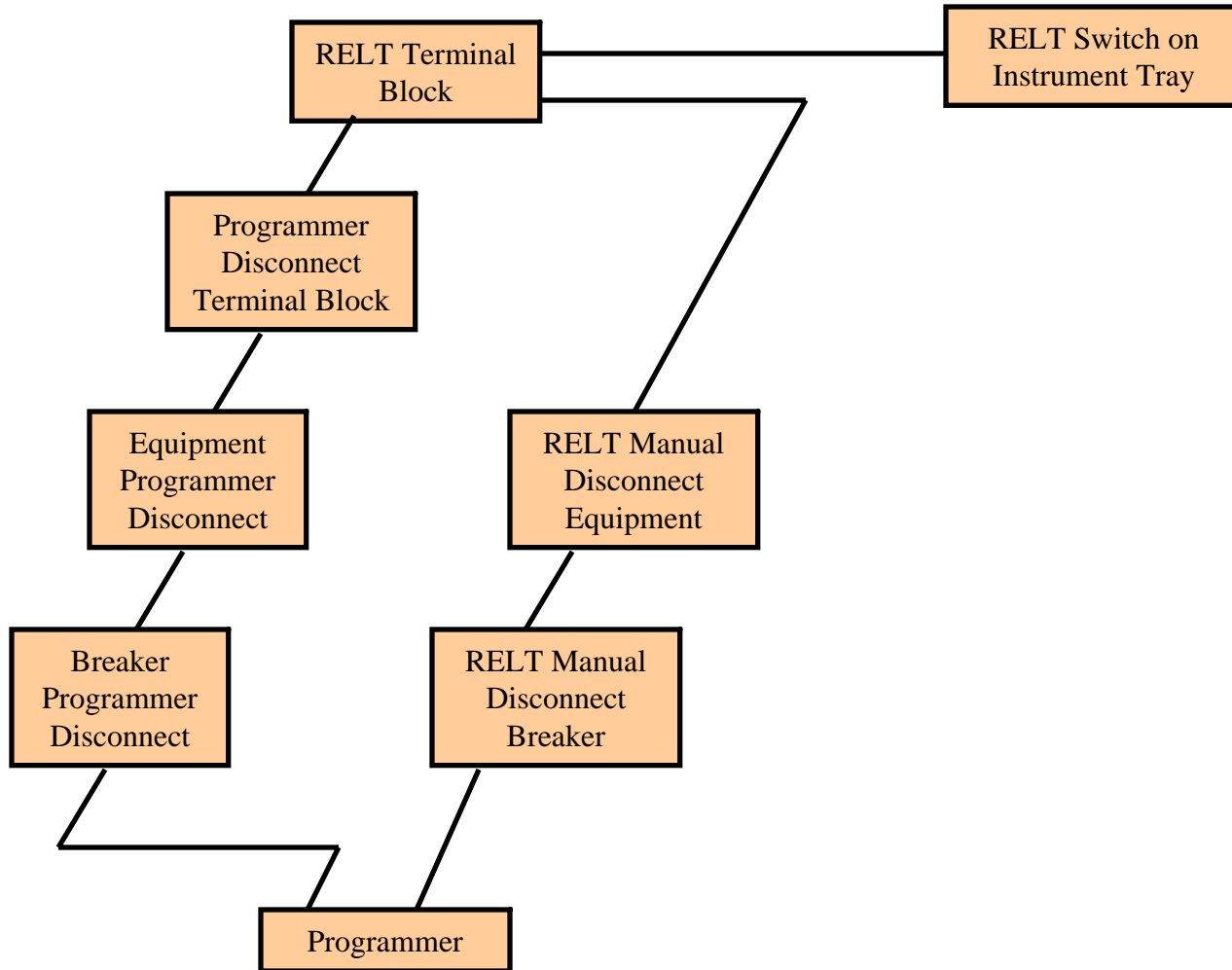

Block Diagram of wiring harness

# RELT Switch Wire Harness

AKD8

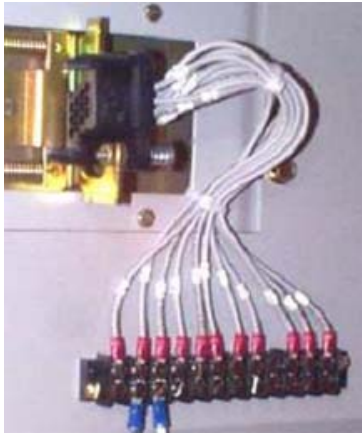

For 24VDC

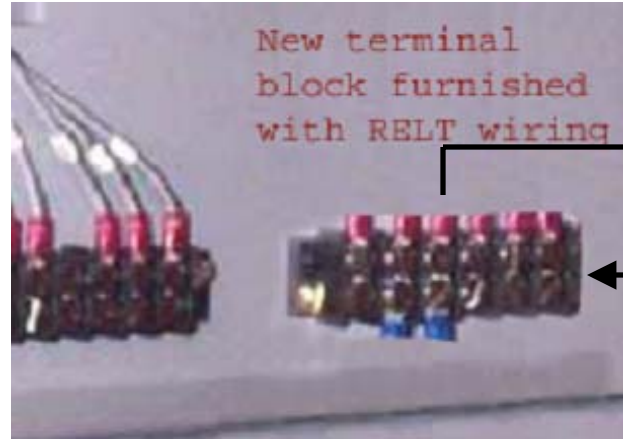

For RELT wiring



Programmer Plug

For breaker with programmer disconnect

# RELT Switch Wire Harness

AKD8

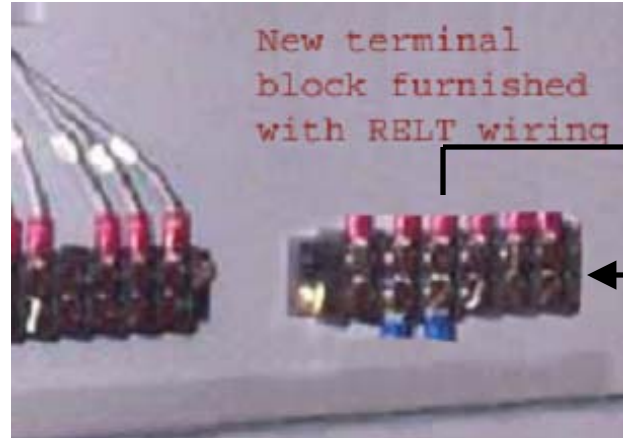

For 24VDC



For RELT wiring



Programmer Plug

For breaker without programmer disconnect

1

# RELT Switch Wire Harness

AKD8

Pin #1 location

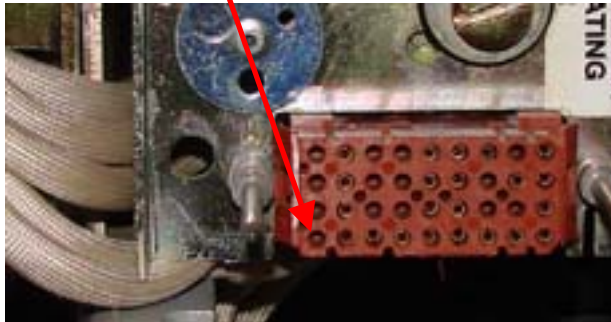

Front View of Programmer Plug

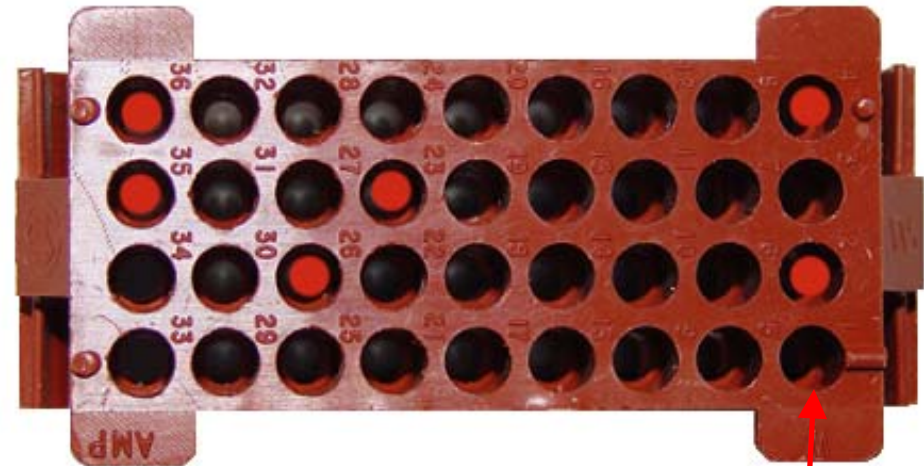

Rear View of Programmer Plug

Pin #1 location

Programmer Pin	Function
30	output +
27	output -
4	input +
2	input -
36	24VDC+
35	24VDC-

2

# RELT Switch Wire Harness

AKD8

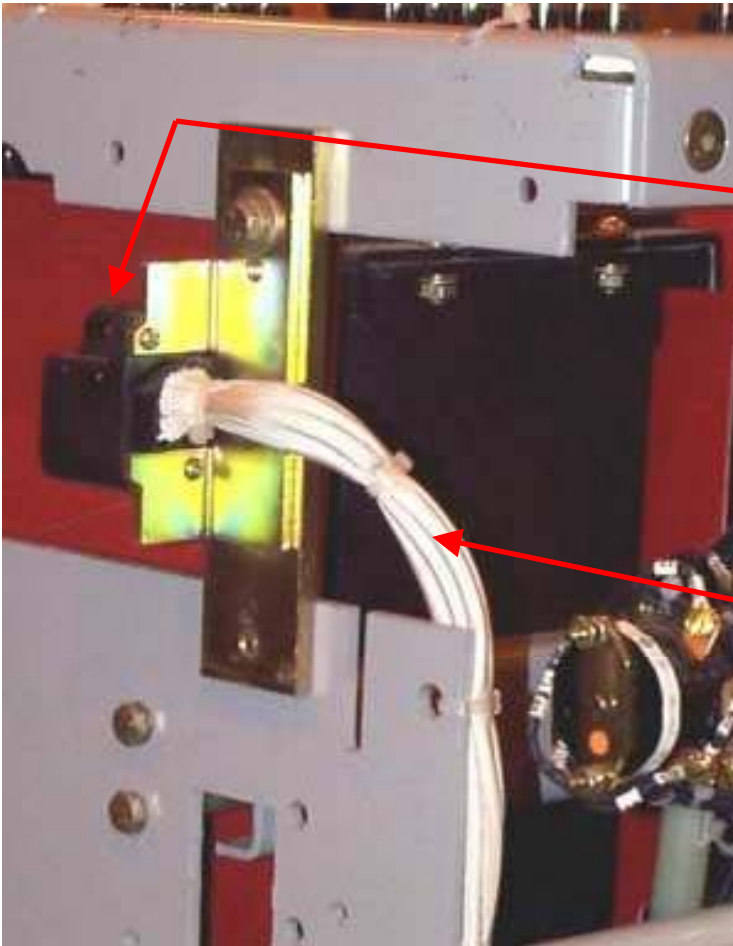

30/50 Breaker	139C4972G003
75/100 Breaker	139C4972G004
30S Breaker	Parts with harness

Breaker Wire Harness Ordering	Catalog Number		
	30/50 Breaker	75/100 Breaker	30S Breaker
Without Air Core CTs, Without 4th Wire	425D366G079	425D385G071	343L870G025
Without Air Core CTs, With 4th Wire	425D366G081	425D385G079	343L870G027
With Air Core CTs, Without 4th Wire	425D366G080	425D385G072	343L870G026
With Air Core CTs, With 4th Wire	425D366G082	425D385G080	343L870G028

Breaker programmer disconnect

Typical breaker 12 pin programmer disconnect - breaker side

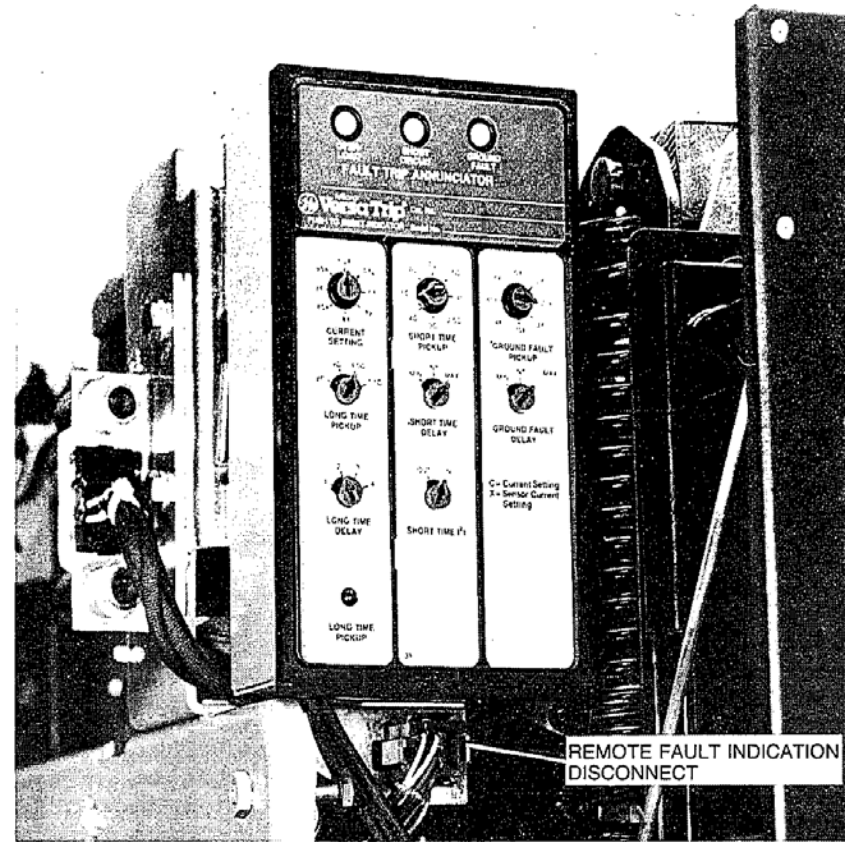
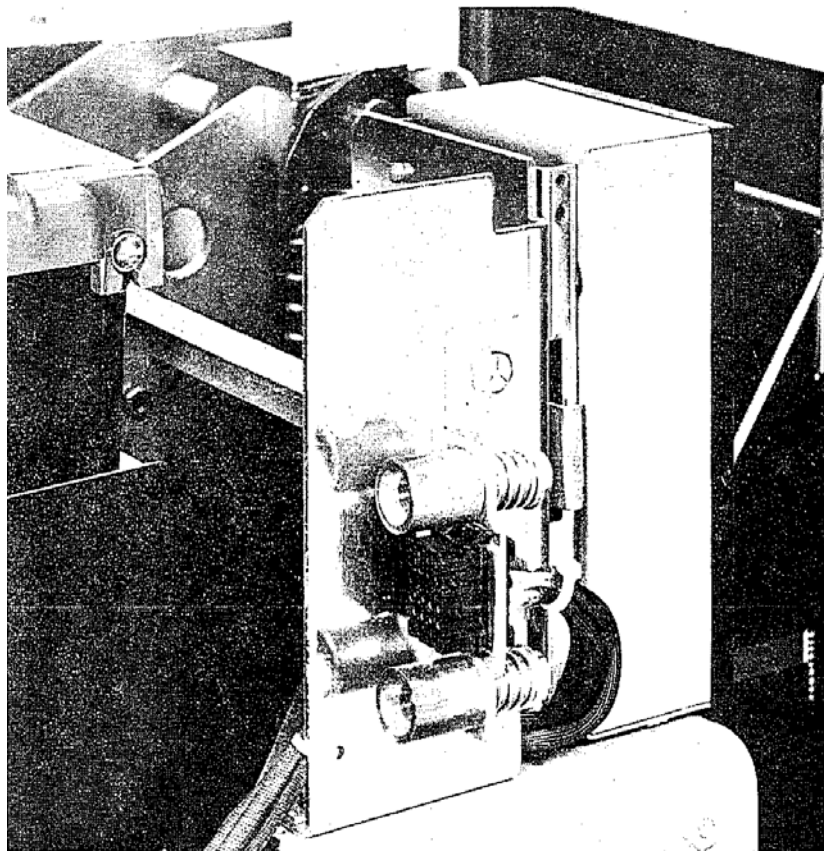

Typical breaker 24 pin programmer disconnect - breaker side

For AKR 30/50 75C149388G017  
 For AKR75/100 75C149388G011  
 For AKR30S 75C149388G018

Programmer Pin Wiring		
Programmer 36 pin plug	Function	12 pin disconnect on side of breaker
5	ZSI IN +	5
6	ZSI IN -	6
7	ZSI OUT +	7
8	ZSI OUT -	8
9	—COMMNET -—	11
13	—COMMNET +—	12
25	VC (voltage conditioner)	10
29	VB (voltage conditioner)	1
33	VA (voltage conditioner)	4
35	Trip unit auxiliary power, + 24V RTN	2
36	Trip unit auxiliary power, - 24V EXTRN	3

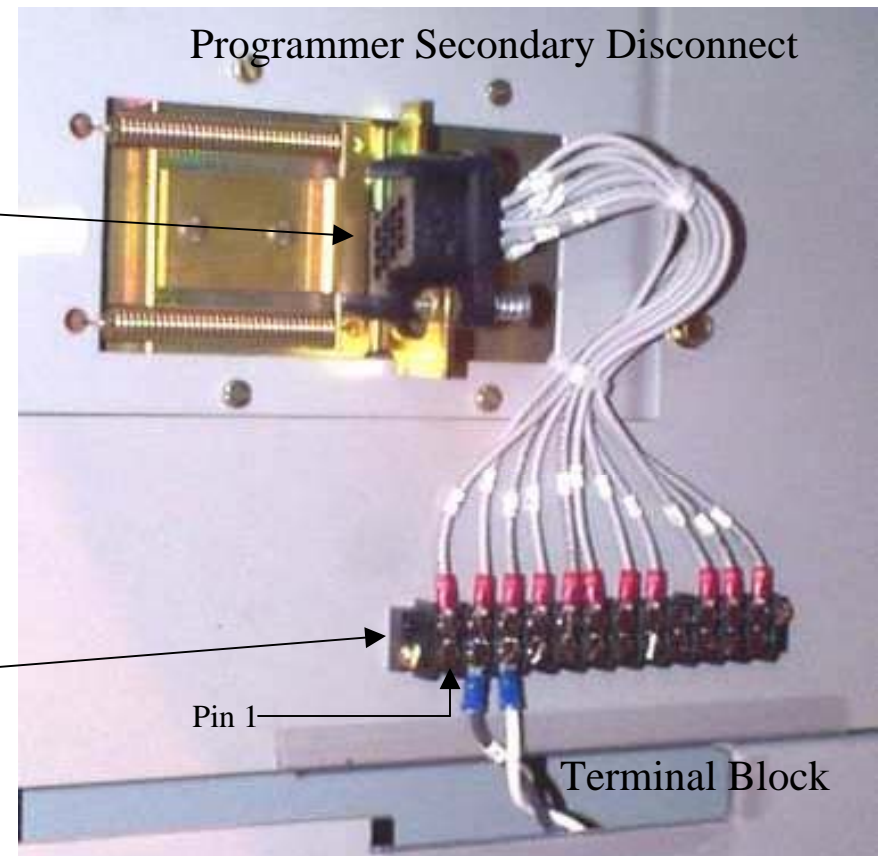

Equipment programmer disconnect

Typical breaker 12 pin programmer disconnect - equipment side

24 pin programmer disconnect plug				
Pin	Pre EPIC programmer		EPIC programmer	
	Function		Function	
1	Short Time	Input +	Short Time	Input +
2		Input -		Input -
3		Output +		Output +
4		Output -		Output -
5	Ground Fault	Input +	Ground Fault	Input +
6		Input -		Input -
7		Output +		Output +
8		Output -		Output -
9		Overload		
10	Fault Trip Indication	Short Circuit		
11		Ground Fault		
12		Overload Pickup		
13				
14				
15				
16				
17			Homnet -	
18			Homnet +	
19				
20			VC	
21			VB	
22			VA	
23			24VDC -	
24			24VDC +	

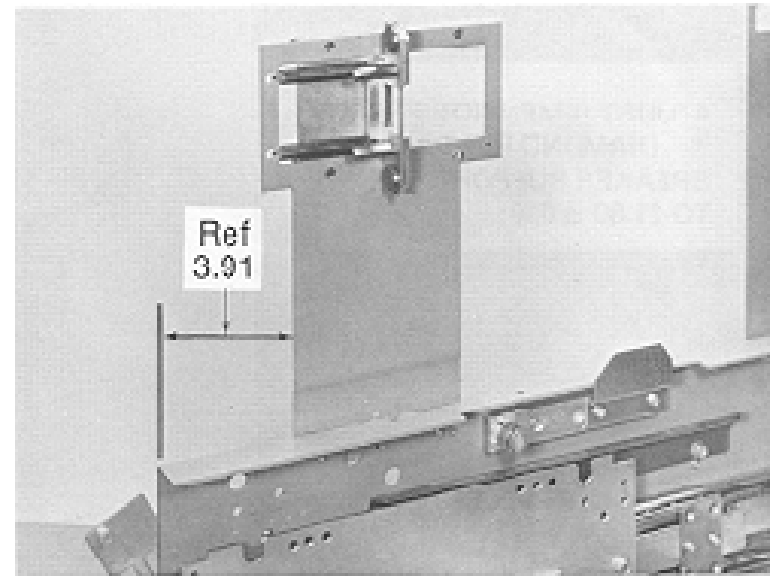
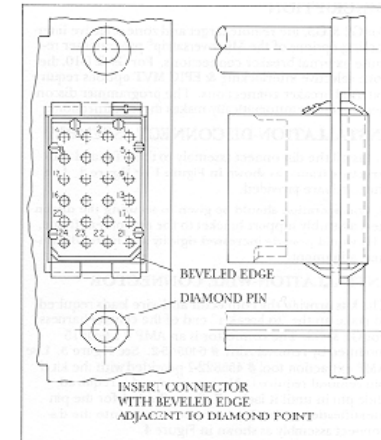

Figure 1 343L406C-2 Disconnect assembly (24 pin) installed.

#### Note

If your current breaker has the 24 pin disconnect you need to see if it has pins and wires on 23 and 24. If it has an EPIC programmer it would be there. If not those pins and wires will need to be added to get 24VDC to trip unit



Typical breaker 24 pin programmer disconnect - equipment side

4

# RELT Switch Wire Harness

AKD8

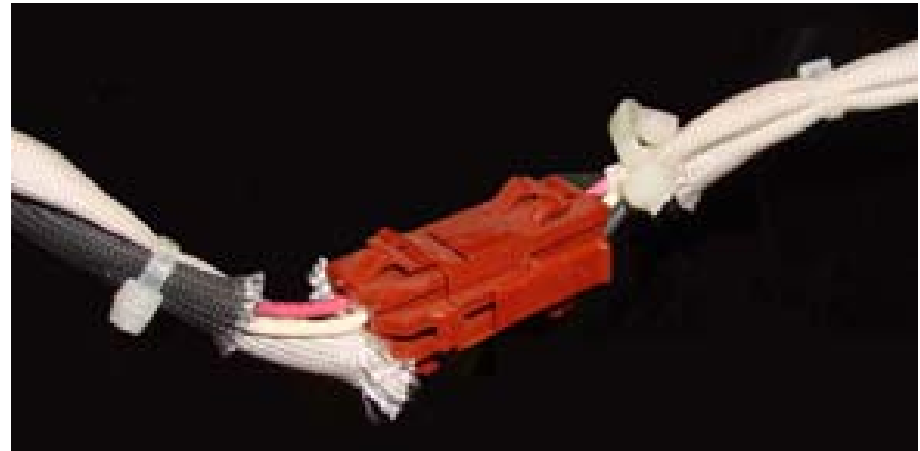
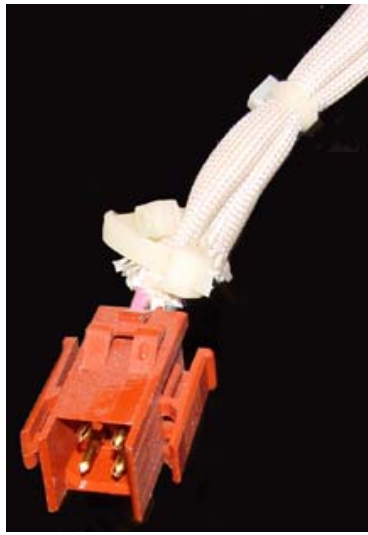
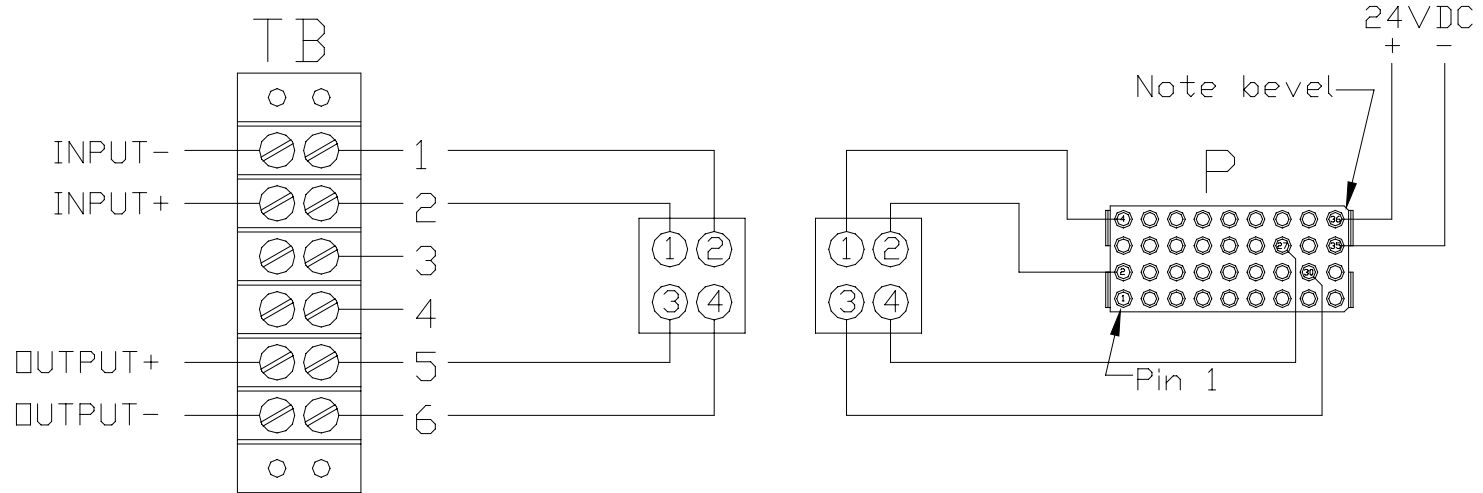

manual disconnect

Wiring to RELT manual disconnect

5

## RELT Switch Wire Harness

AKD8

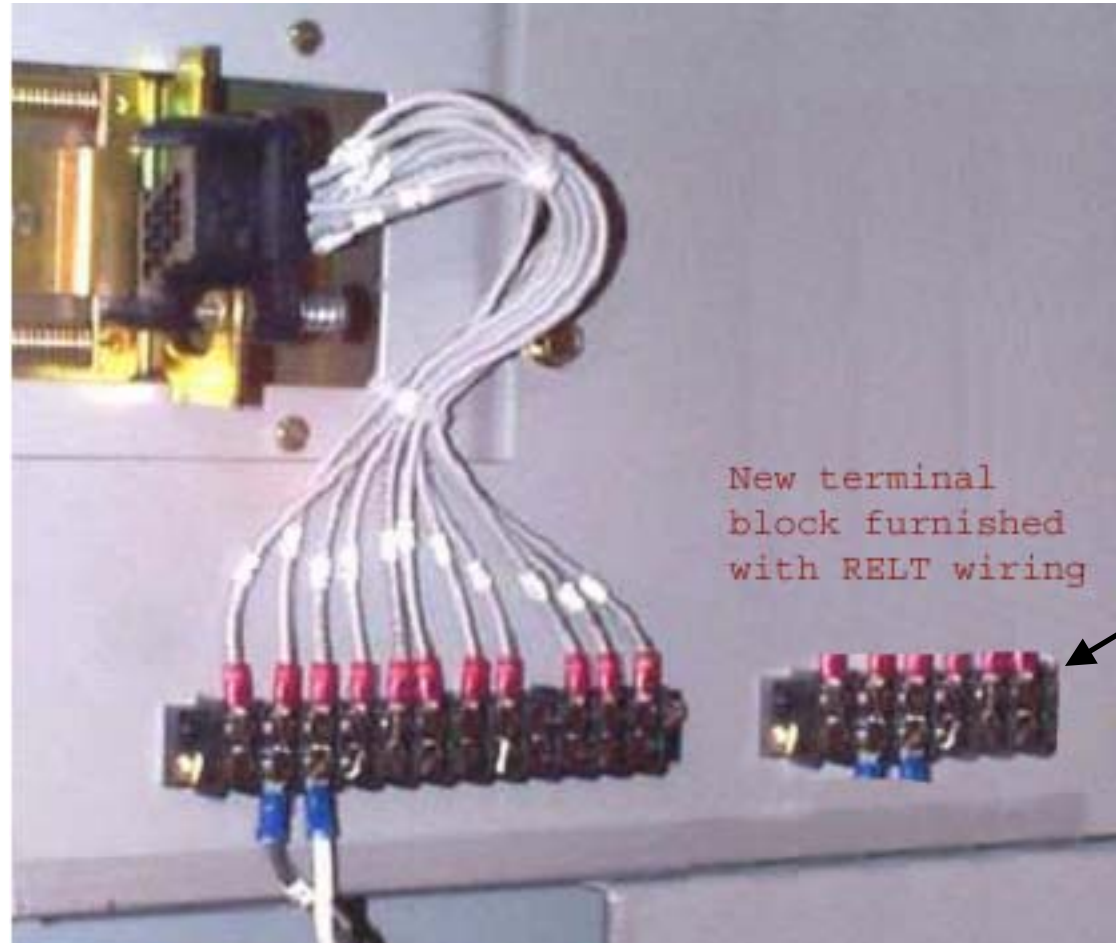

Wiring to RELT manual disconnect

6

## RELT Switch Wire Harness

AKD8

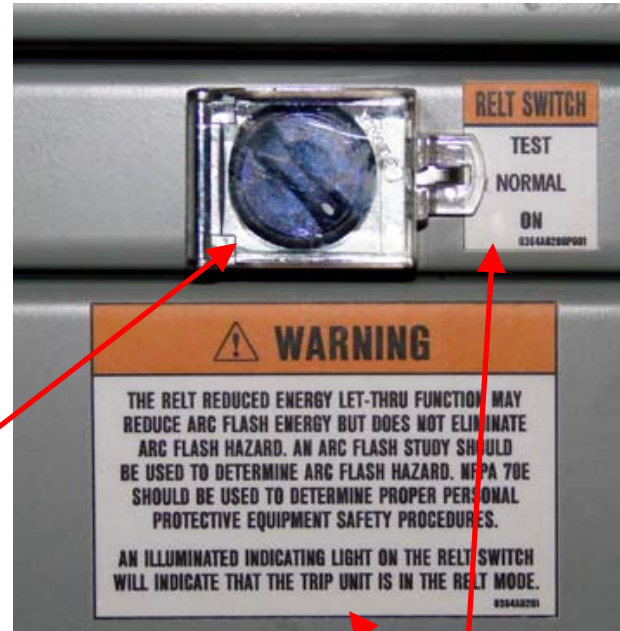

RELT switch on  
instrument tray

RELT labels

Cat # XXXX for switch, harness, labels

Cat # XXXX for instrument tray. Customer can choose to buy new tray or punch old. If buying new tray they will also have to order labels for items on the tray.

# RELT Switch Wire Harness

AKD8

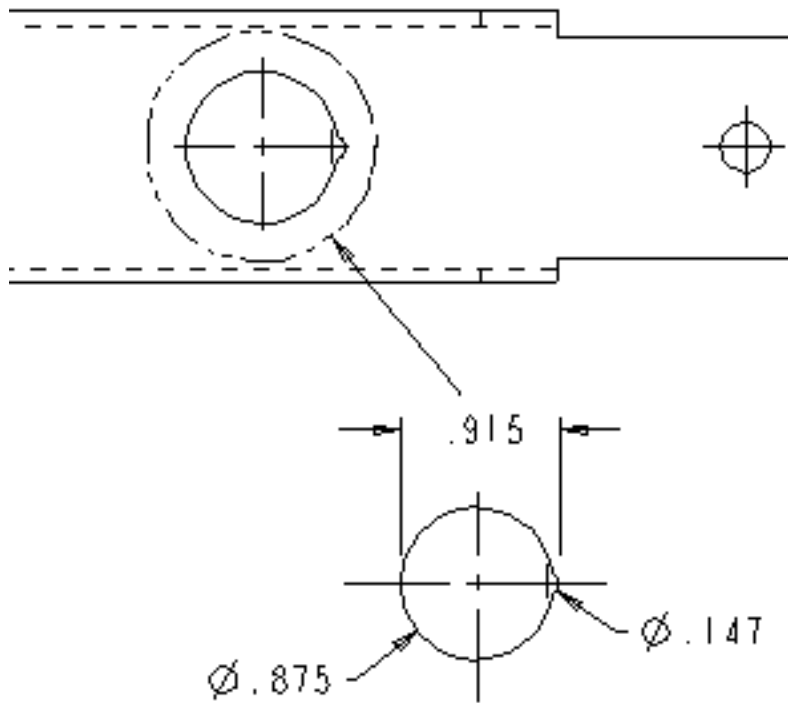

Drilling pattern for RELT Switch

Ref 0217D5267

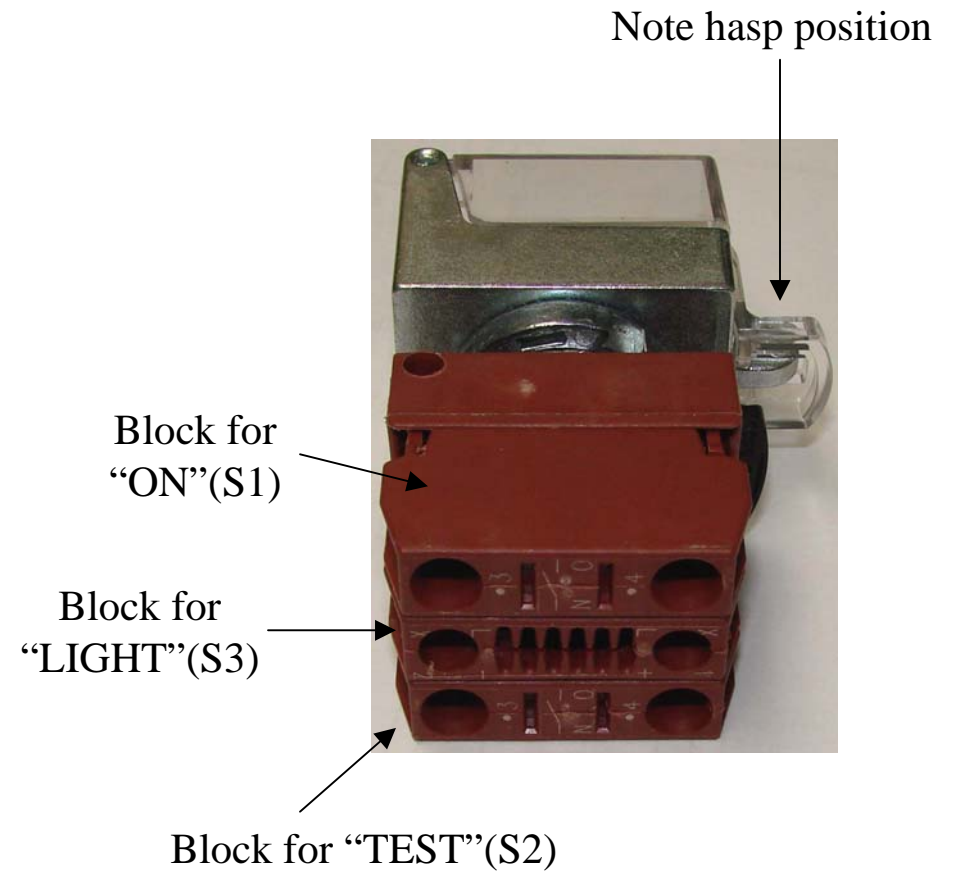

Switch Terminal Location



# RELT Switch Wire Harness

AKD8

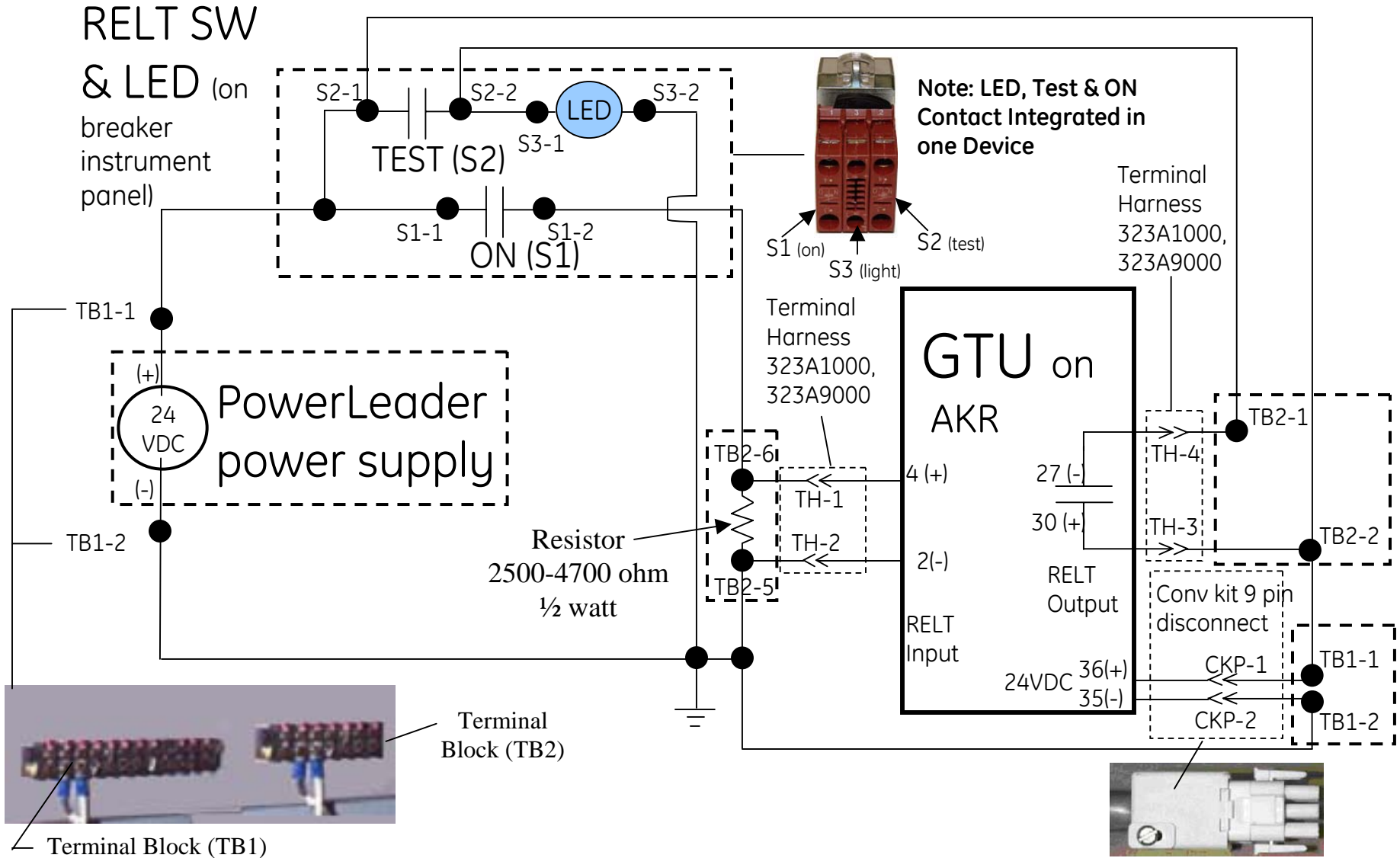

## RELT with Positive Indication & Lamp Test Functionality

For breaker without programmer disconnect. Requires Conversion Kit Plug